

**BS5163
Resilient Seat
GATE VALVES**

**Model 1017FF
Non Rising Stem - Flanged**

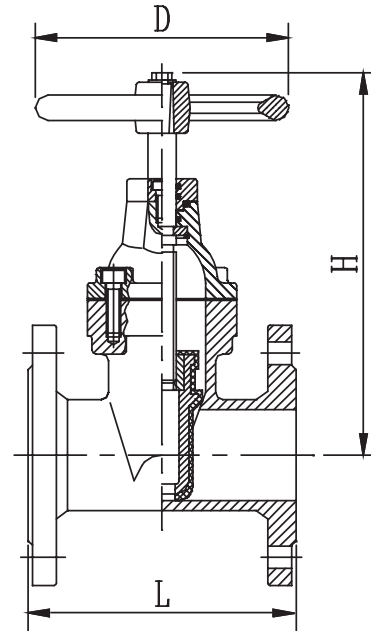

Description:

1. Valve Standard:
 - Comply with BS5163
2. Resilient sealing
3. Packing replaceable under pressure
4. Disc: DI/WRAS EPDM
5. Working Pressure & Temperature:
 - Working Pressure 16 bar
 - Temperature from -20° C to 100° C
6. Flange Type:
 - EN1092-2 PN10/PN16
7. Operator:
 - Handwheel, Operating Nut or Gear Operator
8. Fusion bond epoxy coated internally and externally, AWWA C550/WRAS
9. Face to face length in accordance with EN558-1 basic series 3

DIMENSIONAL DATA

Size (mm)	Part No.	L	H w/Handwheel	D	Approx. Wgt. (kg)
50	M1017FF-50	178	258	165	15
65	M1017FF-65	191	262	185	17
80	M1017FF-80	203	305	200	20
100	M1017FF-100	229	350	220	26
125	M1017FF-125	254	265	250	33
150	M1017FF-150	267	436	285	46
200	M1017FF-200	292	535	340	70
250	M1017FF-250	330	635	405	105
300	M1017FF-300	356	721	460	159
350	M1017FF-350	381	783	520	218
400	M1017FF-400	406	902	580	280
450	M1017FF-450	432	980	640	390
500	M1017FF-500	457	1092	715	504
600	M1017FF-600	508	1275	840	730

Dimensions in mm

MATERIAL LIST

Description	Material
Body	Ductile Iron
Bonnet	Ductile Iron
Bonnet Gasket Bolt	SS 316
Wedge	DI with EPDM Coated - WRAS
Wedge Nut	Brass
Thrust Collar	Brass
Stem Nut	Brass
Stem	SS 420/SS 304/SS 316
O-Ring	EPDM/NBR - Commercial
Gasket	EPDM/NBR - Commercial
Gland	Brass
Wrench Nut	Ductile Iron
Handwheel	Ductile Iron
Handwheel Bolts	SS 304
Dust Cap	NBR/EPDM



WARNING: This product can expose you to chemicals including lead, which is known to the State of California to cause cancer and birth defects or other reproductive harm. For more information go to www.P65Warnings.ca.gov.



United Water Products
 5355 Ramona Blvd., Jacksonville, FL 32205
 TEL: 877-766-4459 FAX: 877-766-4458
 Website: www.unitedwaterproducts.com